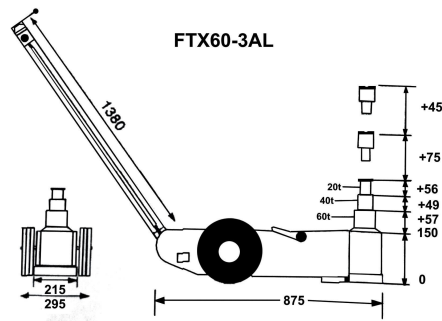

FORTEX®

REFERENCIA

530000475

CÓDIGO EAN

8423640152755

ARTÍCULO

FTX60-3al professional pneumatic cat 20/40 / 60ton.

DESCRIPCIÓN
DATOS TÉCNICOS

Capacidad ton.	60/40/20 ton.
Air	8 - 12 psi
Minimum height	150 mm.
Height lifting	60TON: 57 / 40TON: 49 / 20TON: 56 mm.
Expansion	75 + 45 mm.
Maximum height	- mm.
Peso Neto/Bruto	64/67 kg.